

Contents

1	About this manual	2			
1.1	Information about the manual	2	6.5	Attach glass	14
1.2	Other applicable documents	2	6.6	Attach sound-absorbing material and frameless textile banner	15
1.3	Target group	2	6.6.1	Attach sound-absorbing material	15
1.4	Symbols used	2	6.6.2	Attach frameless textile banner	16
1.4.1	Safety instructions	2	6.7	Complete mounting	17
1.4.2	Further labeling	2	7	Maintenance and care	17
2	Safety	2	7.1	Maintenance instructions	17
2.1	Intended use	2	7.2	Cleaning instructions	17
2.2	Foreseeable misuse	3	8	Disassembly and disposal	17
3	Product information	3			
3.1	Example of a UNIQUIN unit with acoustic element	3		Link to the installation animation EN (QR Code)	20
3.2	Parts included	3			
3.2.1	Acoustic element frame	4			
3.2.2	Adapter (optional)	4			
3.3	Example of mounted acoustic elements	4			
3.4	Technical data	5			
3.4.1	Base profile	5			
3.4.2	Fixed glazing adapter	5			
3.4.3	Clearances	6			
3.4.4	Textile banner and sound absorption	6			
4	Storage and transport	6			
5	Mounting preparation	7			
5.1	Tools for mounting	7			
5.2	Installation situation for mounting the acoustic element	7			
5.3	Check assembly location	8			
5.4	Attach silicone seal	8			
6	Mounting	8			
6.1	Pre-mount the acoustic element frame	9			
6.2	Mount the acoustic element frame in the unit	11			
6.3	Mount overpanel (optional)	13			
6.4	Siliconize	14			

UNIQUIN

Acoustic Element

1 About this manual

1.1 Information about the manual

This manual describes the mounting of a UNIQUIN acoustic element as part of a UNIQUIN partition wall system and provides maintenance and care information.

Further unit components and mounting instructions may be required to complete the UNIQUIN partition wall unit's mounting according to the project-related unit drawing, e.g. for the door frame unit with hinges and overpanel. The illustrated unit components and configurations are exemplary and do not show every possible mounting situation.

1.2 Other applicable documents

The following technical documents for the product should be noted:

- The project-related unit drawing
- The mounting instructions of all unit components
- The UNIQUIN system manual

1.3 Target group

The target group of these mounting instructions is qualified personnel specially trained in mounting glass.

1.4 Symbols used

1.4.1 Safety instructions

Safety instructions are marked with signal words. The safety instructions are introduced by symbols that express the extent of the hazard, e. g.:



WARNING

This signal word indicates a situation of potential risk, which could lead to death or serious injury if not averted.



CAUTION

This signal word indicates a situation of potential risk, which could lead to minor or slight injury if not averted.



ATTENTION

This signal word indicates a situation of potential risk, which could lead to damage to property or the environment if not averted.



TIPS AND RECOMMENDATIONS

This symbol indicates useful information for efficient and trouble-free operation.

1.4.2 Further labeling



Step-by-step graphics



Position numbers for parts in graphics

2 Safety

2.1 Intended use

The product is intended for installation in a UNIQUIN unit to optimize room acoustics.

The product may only be mounted with unit components designed by dormakaba for the installation situation and approved according to the project-related unit drawing.

- The product may only be mounted undamaged and in accordance with the requirements of the assembly location.
- The product may only be mounted by qualified personnel who correspond to the defined target group.
- Only tempered safety glass (TSG) or laminated safety glass (LSG) made of TSG may be installed with the product.
- The use of other composites must be checked by the designer or contractor and the stability assured.
- The product may only be attached to a surface capable of bearing loads using suitable fixing materials.
- The product is only suitable for indoor use.
- The product is suitable for use in tropical countries.

2.2 Foreseeable misuse



WARNING

Danger to life due to falling glass.

Falling glass can lead to life-threatening injuries.

- Glass should not be suspended.
- Mount glass with at least 2 persons.
- Fix glass correctly.
- Follow mounting sequence.
- Clamping profiles on the base profile are not load-bearing.



ATTENTION

Risk of damage due to eccentric vertical loads.

Attaching eccentric vertical loads to the product can cause damage.

- Do not attach any eccentric vertical loads to the product, e.g. by building shelves.

- The product is not suitable for outdoor mounting.
- The product is not suitable for mounting in rooms in which chemicals (e.g. chlorine) are used.

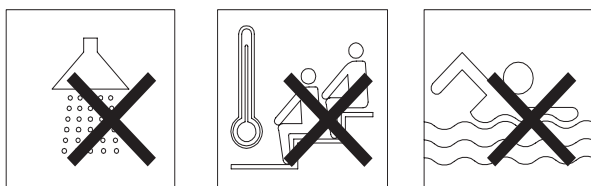

Fig. 1 Not suitable for showers, saunas, baths or salt-water baths

3 Product information

3.1 Example of a UNIQUIN unit with acoustic element

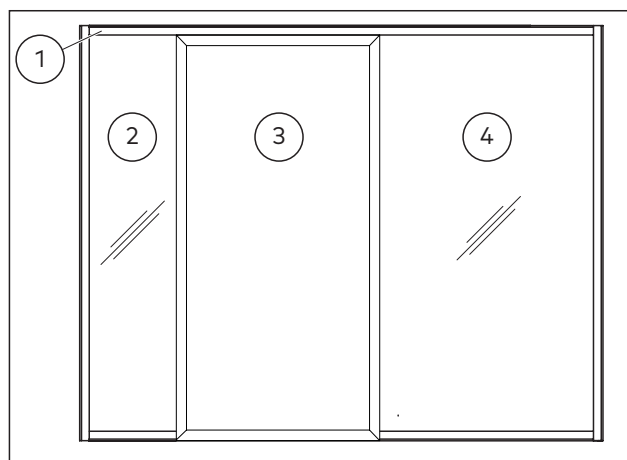

Fig. 2 Example of a UNIQUIN unit with acoustic element between 2 side panels

- 1 Mounting profile
- 2 Side panel left
- 3 Acoustic element
- 4 Side panel right

3.2 Parts included

The delivery quantities and profile lengths vary depending on the product variant or the planned combination of the unit components. The glass is not part of the delivery. The profiles can come in warehouse length, fixed length or in fixed length with oversize.

Fitted textile banners with rubber piping are not included in delivery and must be purchased separately if required.

3.2.1 Acoustic element frame

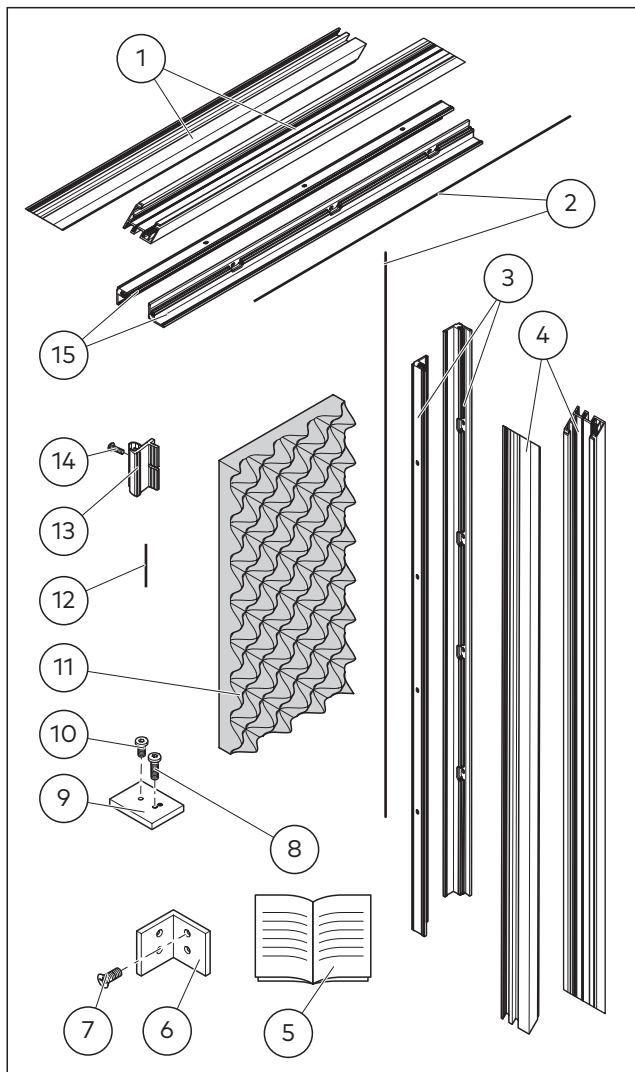

Fig. 3 Parts included for a door frame

- 1 Horizontal sections of the acoustic element frame
- 2 Silicone seals for the base profiles
- 3 Vertical base profiles for the glass mounting
- 4 Vertical sections of the acoustic element frame
- 5 Mounting instructions
- 6 Bracket for the acoustic element frame
- 7 Countersunk screws: M5x20 mm for the bracket
- 8 Hexagon socket screw: M6x12 mm for the base profile
- 9 Spacer for the base profiles
- 10 Torx screw: M5x18 mm for the spacer
- 11 Sound-absorbing material, e.g. acoustic bubble foam (optional)
- 12 Silicon seal for the clamping piece
- 13 Clamping piece for the glass mounting
- 14 Screw for the clamping piece
- 15 Horizontal base profile for the glass mounting
- 16 Foam rubber seal (not illustrated)

3.2.2 Adapter (optional)

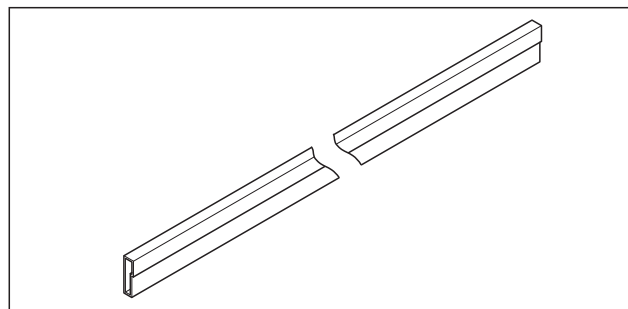

Fig. 4 Fixed glazing adapter (optional)

3.3 Example of mounted acoustic elements

Acoustic element frame in the UNIQUIN unit:

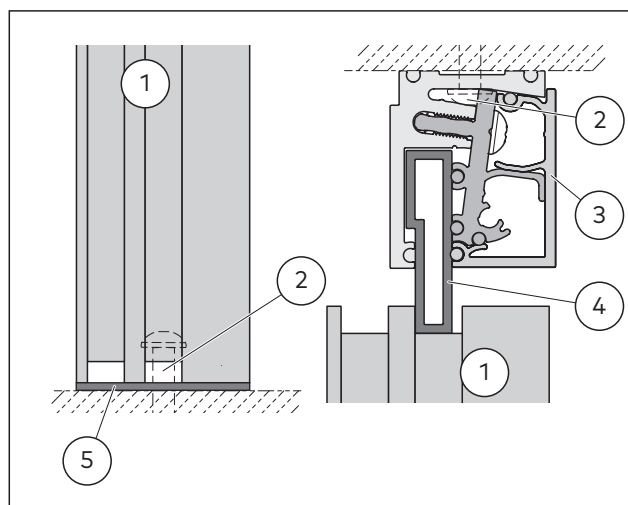

Fig. 5 Example of mounted acoustic element frames

- 1 Acoustic element frame
- 2 Suitable fixing materials (not included in delivery)
- 3 End profile
- 4 Fixed glazing adapter
- 5 Partition wall hinge (not included in delivery)

Base profile with glass in the acoustic element frames:

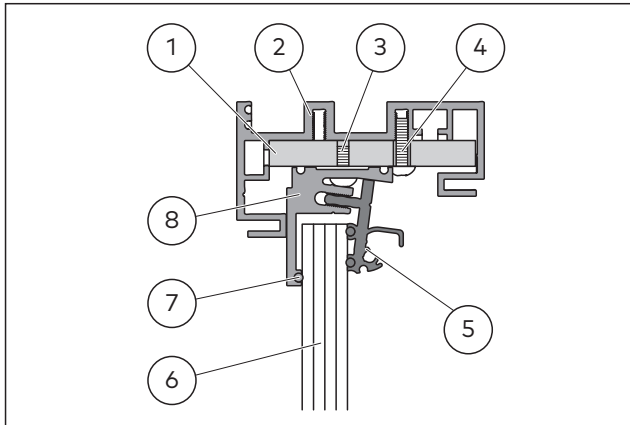

Fig. 6 Example of a mounted base profile with glass in the acoustic element frames:

- 1 Spacer
- 2 Acoustic element frame
- 3 Hexagon socket screw: M6x12 mm for the base profile
- 4 Torx screw: M5x18 mm for the spacer
- 5 Clamping piece with silicone seal
- 6 Glass
- 7 Silicone seal
- 8 Base profile

3.4 Technical data

3.4.1 Base profile

For glass thicknesses from 10 mm to 18 mm:

- i** **TIPS AND RECOMMENDATIONS**
Only the 46 mm base profiles and a maximum glass thickness of 10 mm to 18 mm can be used.

- i** **TIPS AND RECOMMENDATIONS**
Use the same glass thickness in the acoustic element as in the side panels in the same alignment.

Glass recess in 46 mm base profile: 23 mm ± 2 mm

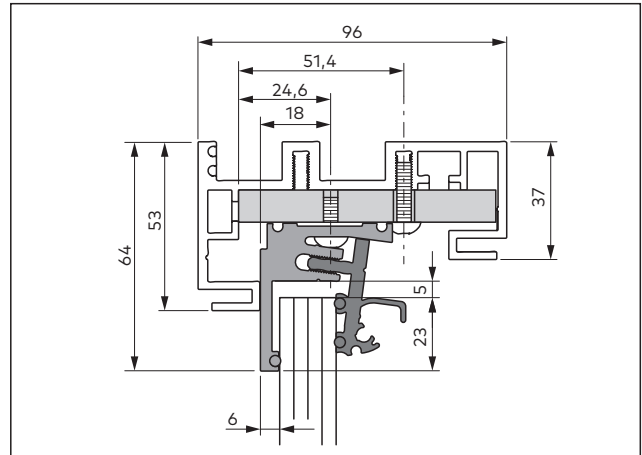

Fig. 7 Dimensions in mm for glass thicknesses 10 to 18 mm

3.4.2 Fixed glazing adapter

Example of an installation situation with mounting profile and fixed glazing adapter:

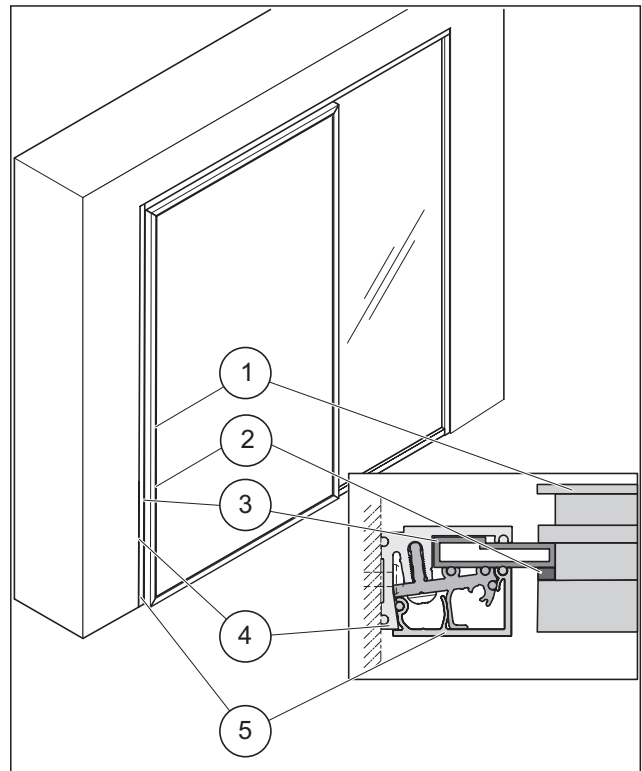

Fig. 8 Example of an installation situation with mounting profile and fixed glazing adapter

- 1 Acoustic element frame
- 2 Foam rubber seal
- 3 Fixed glazing adapter
- 4 Base profile
- 5 End profile

Dimensions of the fixed glazing adapter:

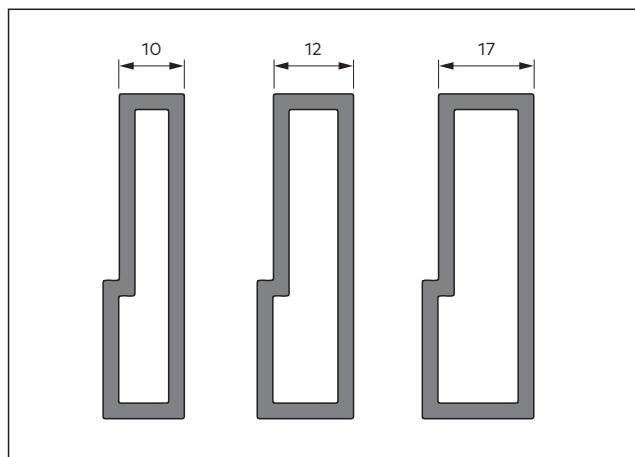

Fig. 9 Fixed glazing adapter dimensions

3.4.3 Clearances

Observe the following distance dimensions during mounting:

- Between glass elements 5 mm ± 2 mm, siliconized
- Glass recess of a side panel in the acoustic element 11 mm ± 1 mm

3.4.4 Textile banner and sound absorption

Dimensions in height:

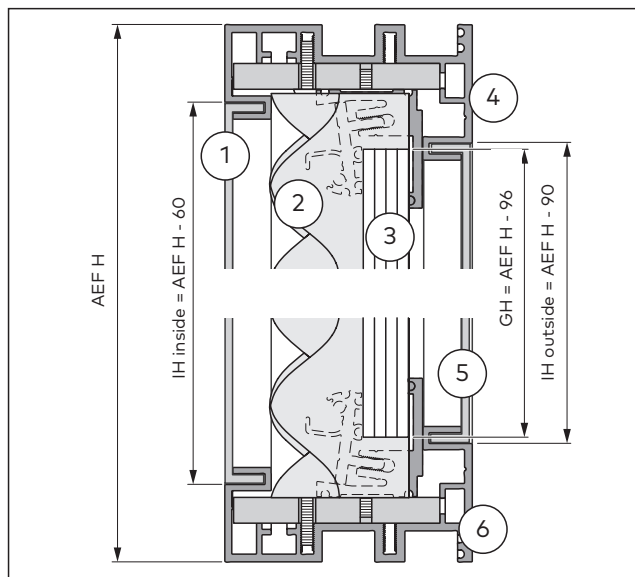

Fig. 10 Height of the acoustic element frame, textile banner and sound-absorbing material

- 1 Textile banner inner side
 - 2 Sound-absorbing material
 - 3 Acoustic element frame top
 - 4 Textile banner outer side
 - 5 Acoustic element frame bottom
- AEF H** Height of acoustic element frame
IH Image height of textile banner
GH Glass height

Dimensions in width:

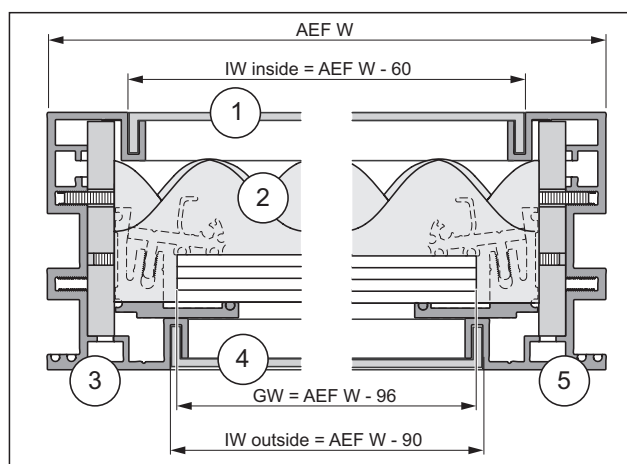

Fig. 11 Width of the acoustic element frame, textile banner and sound-absorbing material

- 1 Textile banner inner side
 - 2 Sound-absorbing material
 - 3 Acoustic element frame left
 - 4 Textile banner outer side
 - 5 Acoustic element frame right
- AEF W** Width of acoustic element frame
IW Image width of textile banner
GW Glass width



TIPS AND RECOMMENDATIONS

For information on the sound-absorbing material and the frameless textile banner, see Chapter 6.6.

4 Storage and transport



CAUTION

Risk of injury due to heavy weight.

Lifting heavy components can result in injury.

- Lift the heavy components together with several persons or a suitable lifting device.



CAUTION

Risk of crushing and collision due to unsecured components.

Unsecured components can lead to crushing and impact injuries during transport.

- Wear personal protective equipment.
- Secure components adequately during transport.



ATTENTION

Risk of damage to the glass components by contact with hard materials (e.g. glass, metal, concrete).

The contact may cause conchoidal fractures, damage the edges and/or break the glass of the glass components.

- Protect glass edges with spacers.
- Do not install damaged glass components.



ATTENTION

Risk of damage during transport.

Unsecured components may be damaged during transport.

- Secure components adequately during transport.

5 Mounting preparation



CAUTION

Risk of injury due to sharp edges.

Contact with cut edges can lead to cuts.

- Wear protective gloves.
- Deburr cutting edges.
- Blunt edges, e.g. with silicone.
- Secure cut edges against contact.

5.1 Tools for mounting

- Torx angle screwdriver
- Spirit level
- Hexagonal socket set
- Drilling machine
- Vacuum lifting tool
- Wooden blocks
- Torque wrench
- Knife or scissors

5.2 Installation situation for mounting the acoustic element

Example of an installation situation with side panels

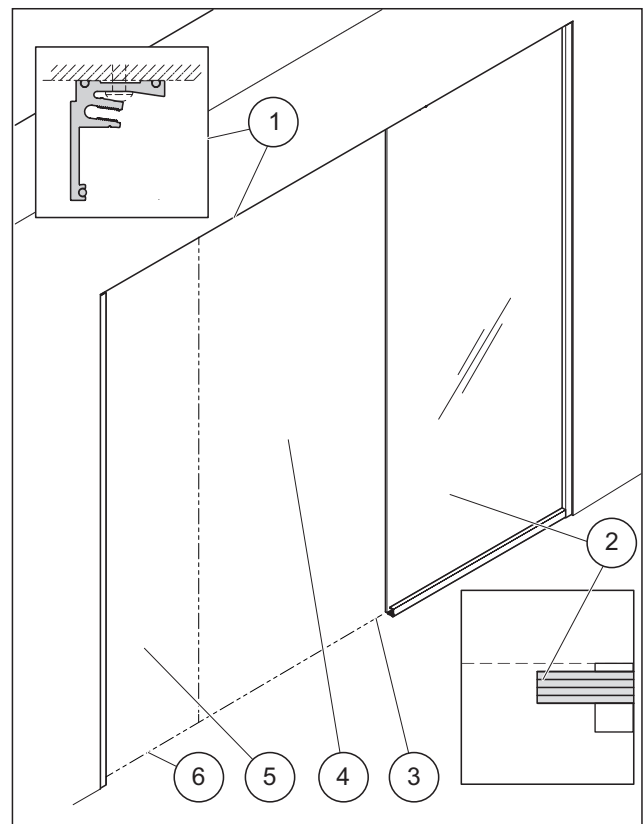

Fig. 12 Example of an installation situation with glass elements and adapter profile

- 1 The mounting profile's base profile
- 2 Side panel (glass) with glass bite for acoustic element
- 3 Unit alignment
- 4 Opening for an acoustic element
- 5 Opening for a side panel
- 6 Place for one of the mounting profile's base profiles



TIPS AND RECOMMENDATIONS

Adapter profiles or wall connection profiles always simulate an installation situation with side panels.

111 inside = KAEFH - 80
 111 inside = AAEFH - 80

**TIPS AND RECOMMENDATIONS**

- Other installation situations can be produced e.g. with adapters (see Chapters 3.2.2 or 3.4.2).
- Combinations of different installation situations in a passage opening are possible, e.g. side panel left, adapter profile above and direct wall connection right.

5.3 Check assembly location

1. Determine the dimensions of the opening for the acoustic element's installation at the assembly location.

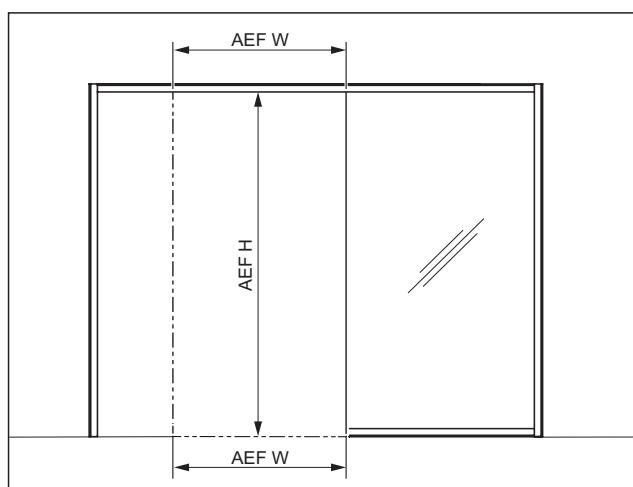

Fig. 13 Example of the opening's dimensions at the assembly location

AEF W Width of acoustic element frame

AEF H Height of acoustic element frame

2. Make sure that the adjacent elements e.g. glass elements are mounted in parallel and at a 90° angle.
3. Make sure that there is an installation situation for the acoustic element's mounting (see Chapter 5.2).

**TIPS AND RECOMMENDATIONS**

It is recommended that before mounting the acoustic element on one side of the opening e.g. no horizontal base profile should be mounted on the ground (Fig. 12, pos. 6).

5.4 Attach silicone seal

1. Identify the groove provided for the silicone seal depending on the profile (see Chapter 3.4).
2. Fit the full length of the silicone seal into the groove provided.
3. Ensure that no tensile forces are exerted on the silicone seal.

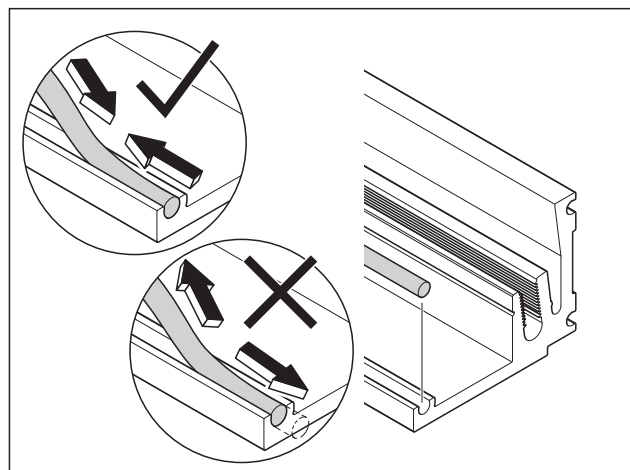

Fig. 14 Attach the silicone seal, e.g. on the base profile

4. If necessary, cut the silicone seal to the required length.

→ **The mounting preparation is completed.**

6 Mounting

**CAUTION****Risk of injury from toppling objects.**

Toppling unsecured components can cause injury.

- Wear personal protective equipment.
- Store and mount objects in a tilt-proof manner.

**CAUTION****Risk of injury by crushing.**

During mounting, high-weight shearing components can cause finger-crushing injuries.

- Wear protective gloves.
- Lift glass with vacuum lifter and insert.

**CAUTION****Risk of injury due to sharp edges.**

Touching cut edges may result in cuts.

- Secure cut edges against contact.
- Wear protective gloves.
- Deburr cutting edges.
- Blunt edges, e.g. with silicone.

**CAUTION****Risk of injury due to heavy weight.**

Lifting heavy components can result in injury.

- Lift heavy components together with several persons and with a suitable lifting device.

**CAUTION****Risk of injury from broken glass during mounting.**

Incorrect mounting can lead to broken glass and injuries.

- Secure the installation site.
- Carry out the mounting with at least 2 people.
- Wear protective clothing.
- Use vacuum lifting tool.
- Store glass on trestles or wooden blocks and ensure that it cannot fall.

**CAUTION****Risk of injury due to insufficient unstable attachment.**

Components must be attached in a sufficiently stable manner. The clamping profiles on the base profile are not load-bearing.

- Only use components designed and approved by dormakaba according to the project-specific unit drawing.
- Only mount glass on load-bearing floor with wooden blocks.
- Do not suspend glass.
- A silicone joint for the floor attachment is insufficient.

**ATTENTION****Risk of damage due to eccentric vertical loads.**

Attaching eccentric vertical loads to the product can cause damage.

- Do not attach any eccentric vertical loads to the product, e.g. by building shelves.

**TIPS AND RECOMMENDATIONS**

Strict observance of the mounting sequence for all unit components is recommended.

Requirements

- The installation situation is established.
 - The mounting preparation is completed.
1. Only proceed with mounting on a level and clean surface.
 2. Before mounting, prepare all components according to the project-related unit drawing.

6.1 Pre-mount the acoustic element frame

**TIPS AND RECOMMENDATIONS**

Observe the mounting on miter.

1. Insert the spacers into the sections so that there is a spacer for each drill hole in the base section (Fig. 15).

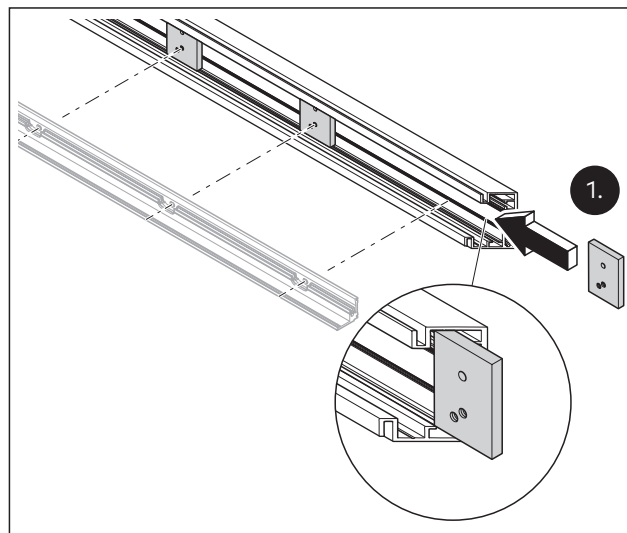

Fig. 15 Insert the spacers into the sections of the acoustic element frame for the base profiles

2. Insert the angle pieces into each horizontal section (Fig. 16).

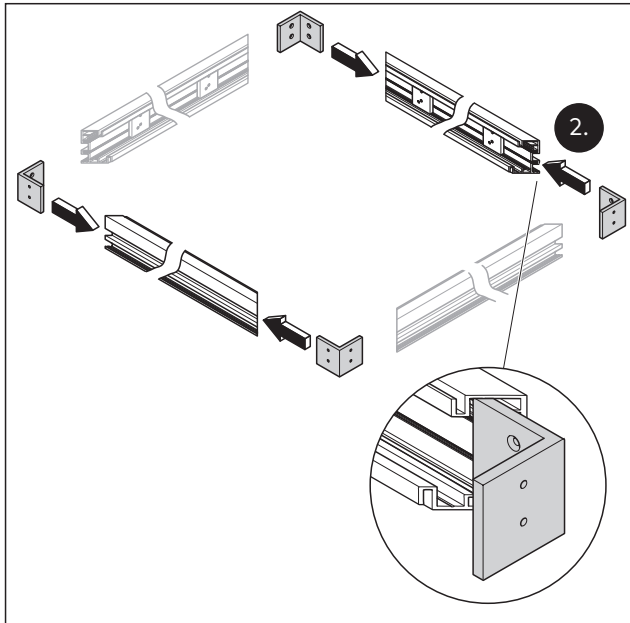

Fig. 16 Insert the angle pieces into each horizontal section

3. Place the vertical sections on the angle pieces
 - ▶ The acoustic element frame is assembled into a rectangle.
4. Make sure that the mitered edges on the outside have no protrusions or sharp edges.
5. Secure the acoustic element frame as a rectangle against sliding, e.g. with a tension belt.
6. Fix the 4 angle pieces in the acoustic element frame with countersunk screws M5x20 mm (Fig. 17).

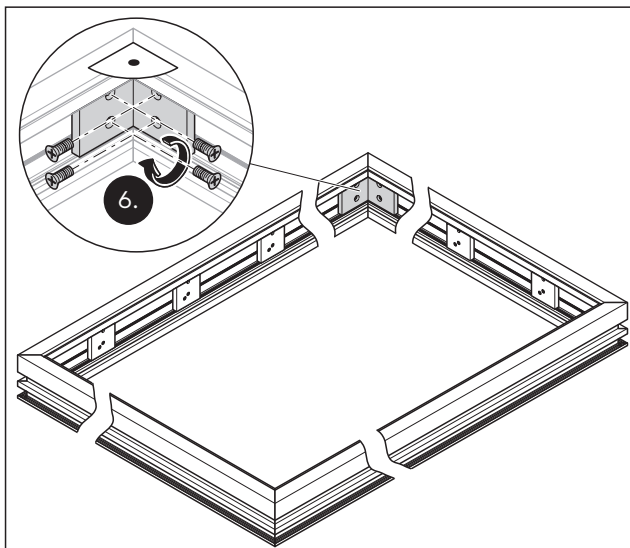

Fig. 17 Connect the angle pieces to the sections

7. Place the upper horizontal base profile and the two vertical base profiles on the spacers (Fig. 18).
8. Fix the upper horizontal base profile and the two vertical base profiles to the spacers with hexagon socket screws M6x12 mm.

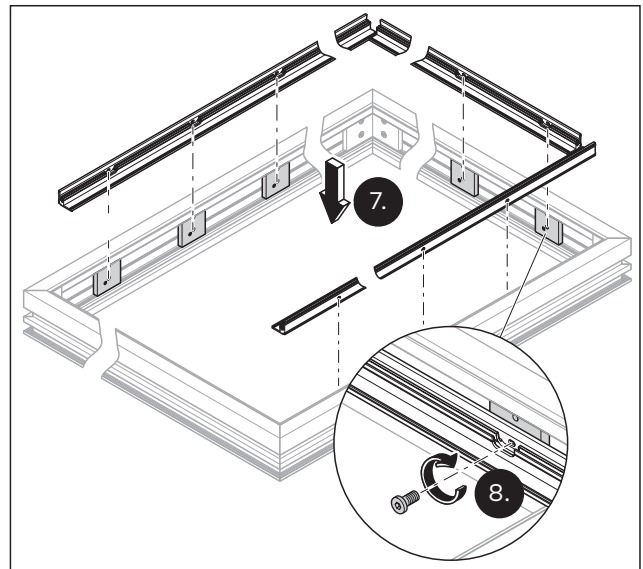

Fig. 18 Attach the base profiles to the acoustic element frames



TIPS AND RECOMMENDATIONS

The lower horizontal base profile is only mounted when the acoustic element frame is mounted on the floor (see Chapter 6.2).

9. Fix the spacers with Torx screws M5x18 mm on the acoustic element frame (Fig. 19).

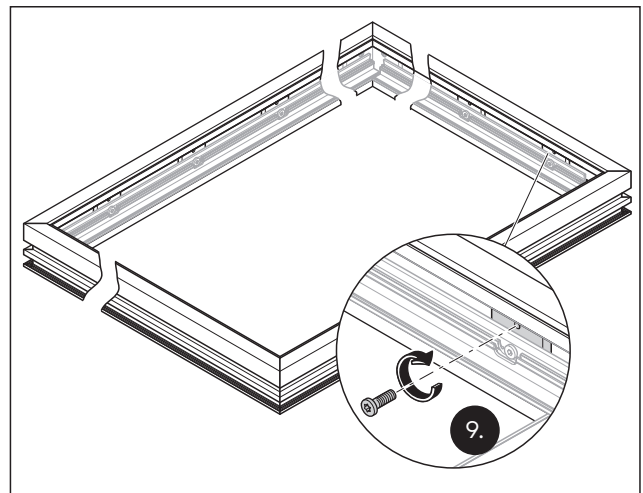

Fig. 19 Fix the spacers onto the acoustic element frame



TIPS AND RECOMMENDATIONS

To meet the requirements of a sound insulation unit, it is imperative to siliconize the joints as described. For silicone use a permanently elastic and UV-resistant silicone. Use an LSG-compatible silicone to siliconize LSG glazing.

- 10. Siliconize all profile edges and impact areas from the inside (Fig. 20).

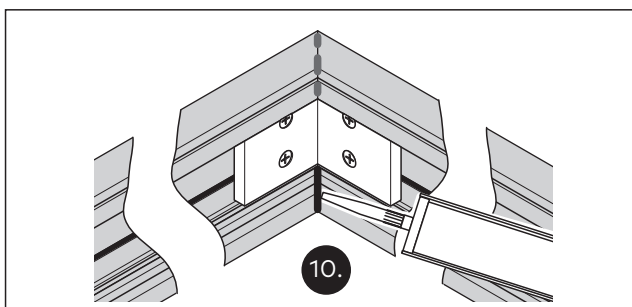

Fig. 20 Siliconize the profile edges and impact areas from the inside

- 11. Siliconize all gaps between the base profile and the acoustic element frame from the inside.



TIPS AND RECOMMENDATIONS

If the acoustic element frame is to be mounted directly on the finished floor, then correctly attach a dividing wall hinge to the acoustic element frame (see Chapter 3.3, Fig. 5 pos. 5).

→ **The acoustic element frame is pre-mounted.**

6.2 Mount the acoustic element frame in the unit

Requirement

- The acoustic element frame is pre-mounted.



TIPS AND RECOMMENDATIONS

The following description shows an example of the installation situation between 2 glass elements and direct floor mounting. For further installation situations (see Chapter 3).

- 1. Observe the alignment of the unit.
- 2. Ensure that a designated side panel is already mounted on one side of the acoustic element.
- 3. Place the acoustic element frame in the opening (Fig. 21).

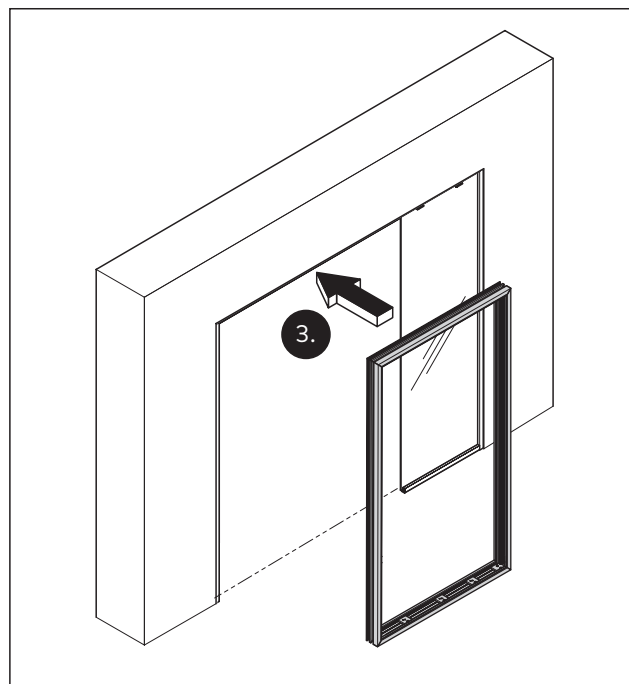

Fig. 21 Place the acoustic element in the opening

- 4. Align the acoustic element frame vertically (Fig. 22).
- 5. Slide the acoustic element frame to the side panel.

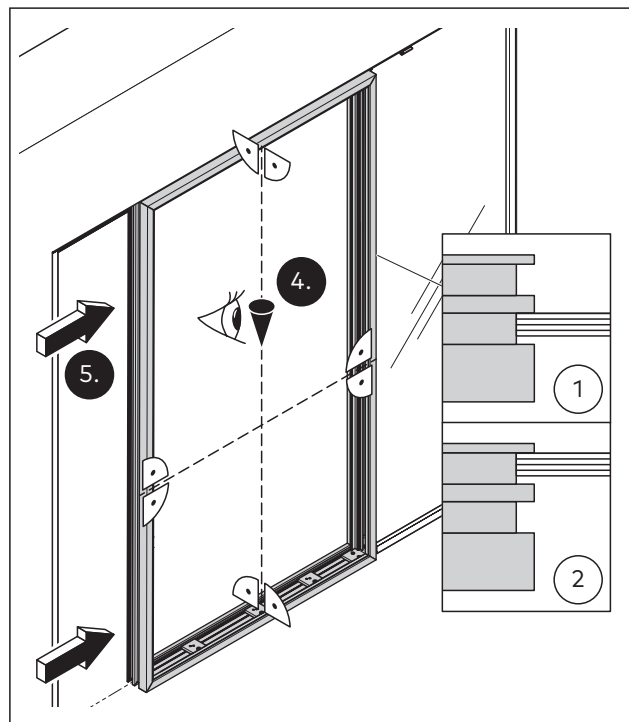

Fig. 22 Align the acoustic element frame

- 1 Mounting center
- 2 Mounting flush with the mounting profile



TIPS AND RECOMMENDATIONS

- These mounting instructions show the acoustic element's central alignment.
- For a flush alignment use the corresponding joint of the acoustic element (see Fig. 22, pos. 2).

6. Correctly siliconize the joint between the glass and the acoustic element frame (see Chapter 6.4)



TIPS AND RECOMMENDATIONS

Determine the diameter of the drill holes as needed for the appropriate fixing materials.

7. Mark at least 3 holes per meter in the lower part of the acoustic element frame (Fig. 23).
8. Drill all marked holes through the acoustic element frame into the ground.

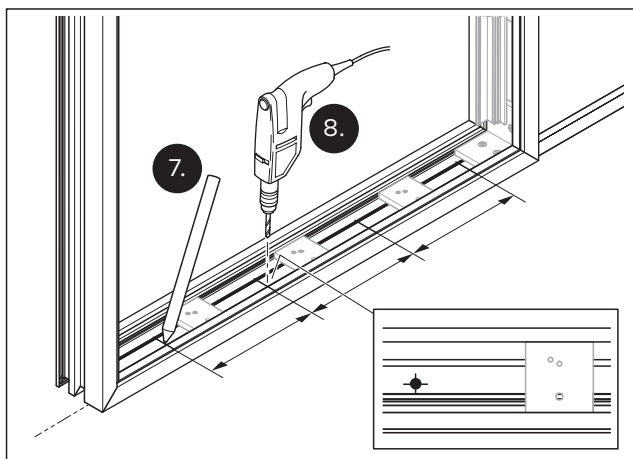

Fig. 23 Drill at least 3 holes per meter through the acoustic element frame into the ground

9. Fix the acoustic element frame to the floor with suitable fixing materials (Fig. 24).

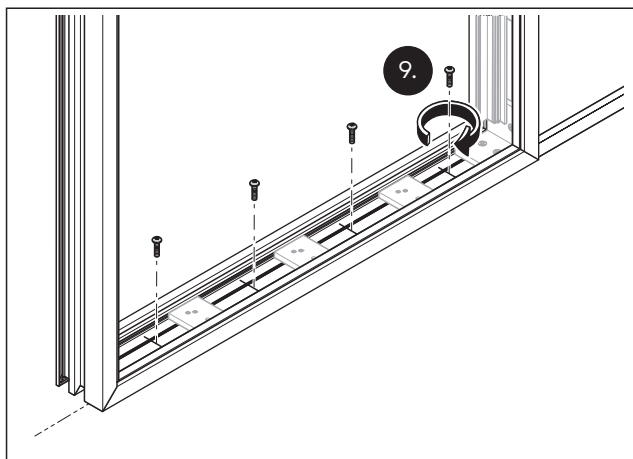

Fig. 24 Secure the acoustic element frame to the floor

10. Hold the adapter profile against the acoustic element and the base profile (Fig. 25).

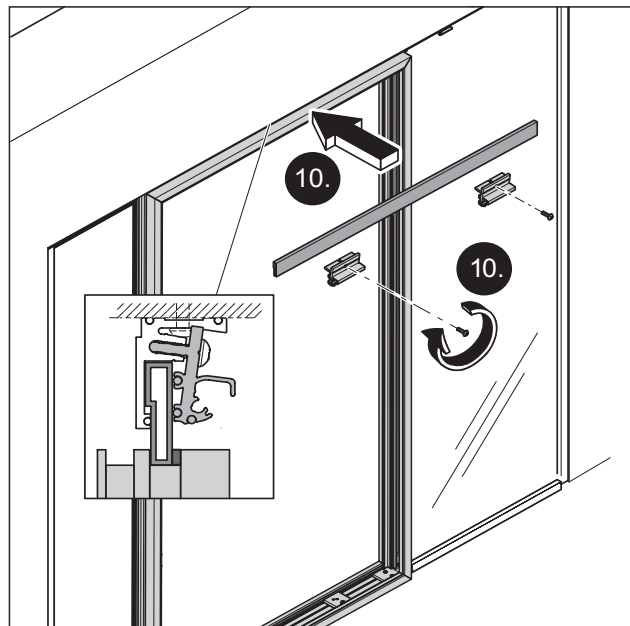

Fig. 25 Attach the adapter profile

11. Press a suitably cut piece of foam rubber seal into the joints on the acoustic element frame (side and top) over the entire length. Make sure the foam rubber seal is flush with the acoustic element frame (Fig. 26).

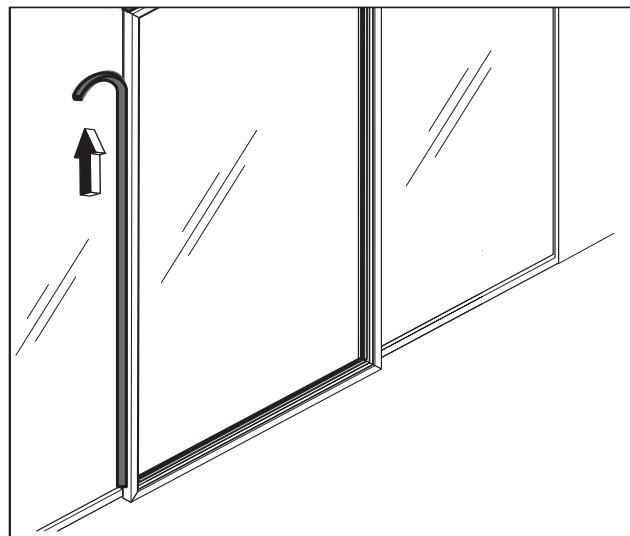

Fig. 26 Example: Mounting the foam rubber seal on left side

12. Fix the adapter profile to the base profile with at least 3 clamping pieces per meter.
13. Place the lower horizontal base profile on the spacers (cf. Fig. 18).
14. Fix the lower horizontal base profile to the spacers with hexagon socket screws M6x12 mm.
15. If necessary, continue mounting the mounting profile according to the mounting instructions.

→ **The acoustic element frame is mounted in the unit.**

6.3 Mount overpanel (optional)



WARNING

Danger to life due to falling glass.

Falling glass can lead to life-threatening injuries.

- Glass should not be suspended.
- Mount glass with at least 2 persons.
- Fix glass correctly.
- Follow mounting sequence.
- Clamping profiles on the base profile are not load-bearing.

Requirements

- The acoustic element frame is mounted in the unit.
 - The mounting profile and all side panels are mounted.
 - The acoustic element frame is capable of bearing loads.
1. Working in a pair, place the overpanel with a vacuum lifting tool on the acoustic element frame (Fig. 27).

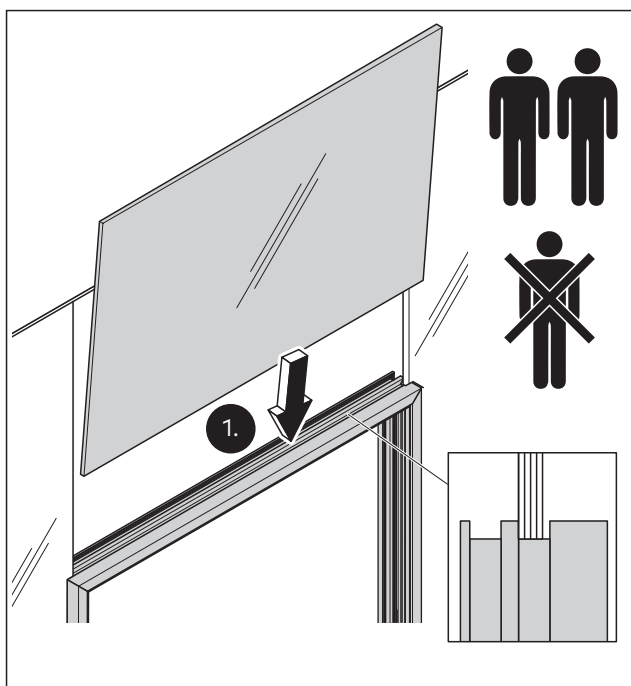

Fig. 27 Place the overpanel on the acoustic element frame

2. Ensure the distance between overpanel and side panels with a spacer (Fig. 27).
3. Align the overpanel with the mounting profile and hold in position.

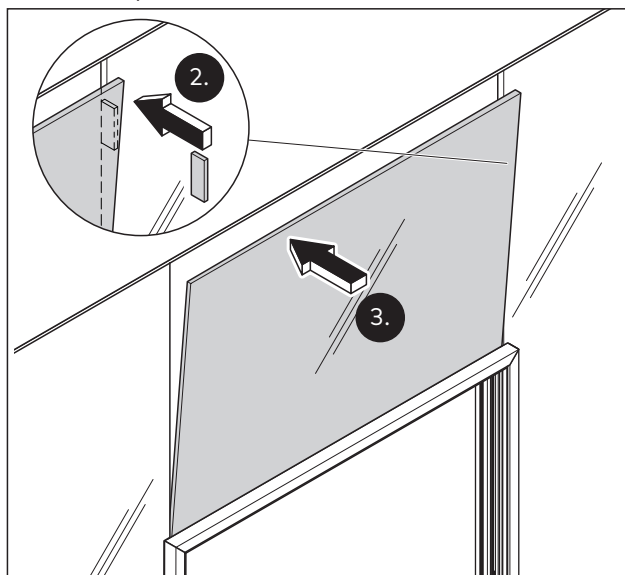

Fig. 28 Align the overpanel and hold in position

4. Press a suitably cut piece of foam rubber seal into the joint between the acoustic element frame and the over panel along the entire length. Make sure the foam rubber seal is flush with the acoustic element frame (Fig. 29).

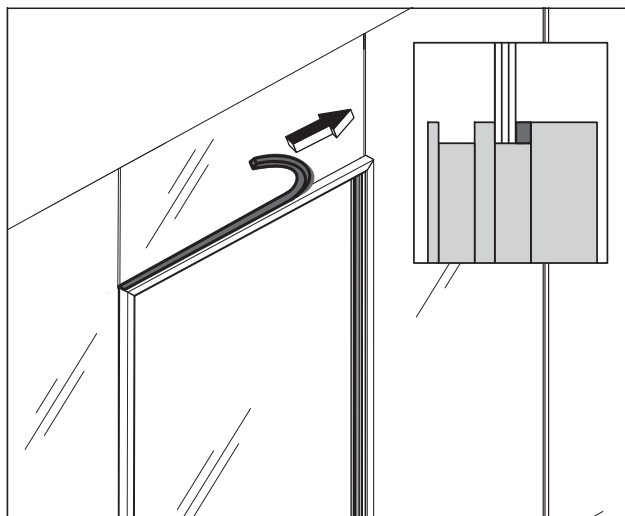

Fig. 29 Mounting the foam rubber seal to the overpanel

5. Attach and fix the clamping pieces in the horizontal mounting profile to the joint between the overpanel and the side panel (Fig. 30).

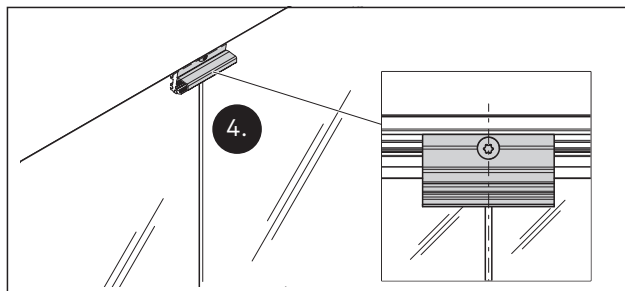

Fig. 30 The position of the clamping pieces on the joint between the overpanel and a side panel

- Mount at least 3 clamping pieces per meter on the base profile of the mounting profile with a torque of 5 Nm (Fig. 31).

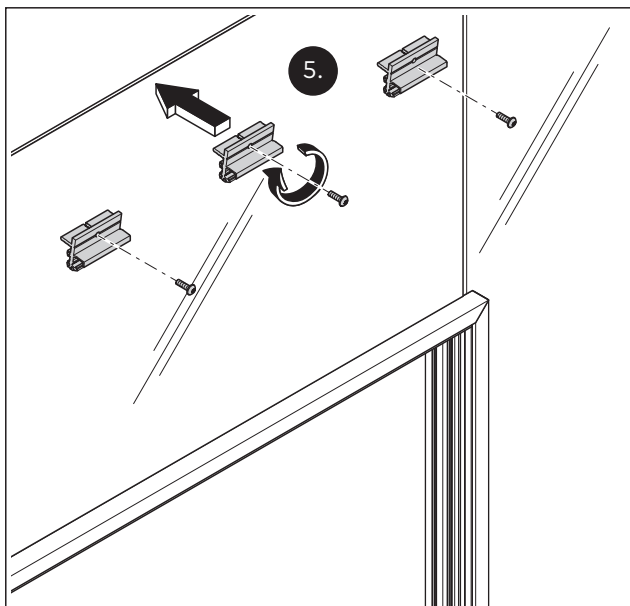

Fig. 31 Fix the overpanel horizontally to the base profile of the mounting profile (top)

- Remove the vacuum lifting tool.

i TIPS AND RECOMMENDATIONS

To meet the requirements of a sound insulation unit, it is imperative to siliconize the joints as described. For silicone use a permanently elastic and UV-resistant silicone. Use an LSG-compatible silicone to siliconize LSG glazing.

- It is recommended to professionally siliconize the entire length of the joints between 2 glasses.
- Mount the end profile above the overpanel according to the mounting instructions of the mounting profile.

→ **The overpanel is mounted.**

6.4 Siliconize

- Correctly siliconize the joints from the profile's inner side (Fig. 32).

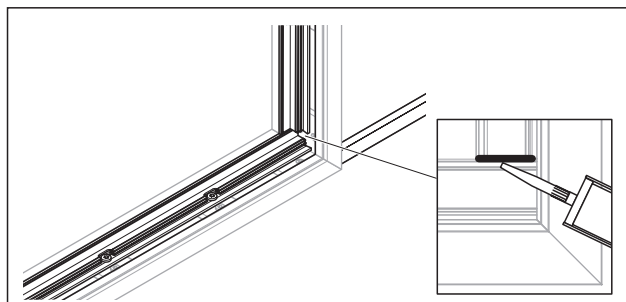

Fig. 32 Example of siliconizing the joints from the profile's inner side

6.5 Attach glass

Requirement

- The acoustic element is mounted in the unit.
- Prepare the lower wooden blocks as needed (Fig. 33).
 - Working in a pair, lift the glass with suitable vacuum lifting tool and place on the wooden blocks below.

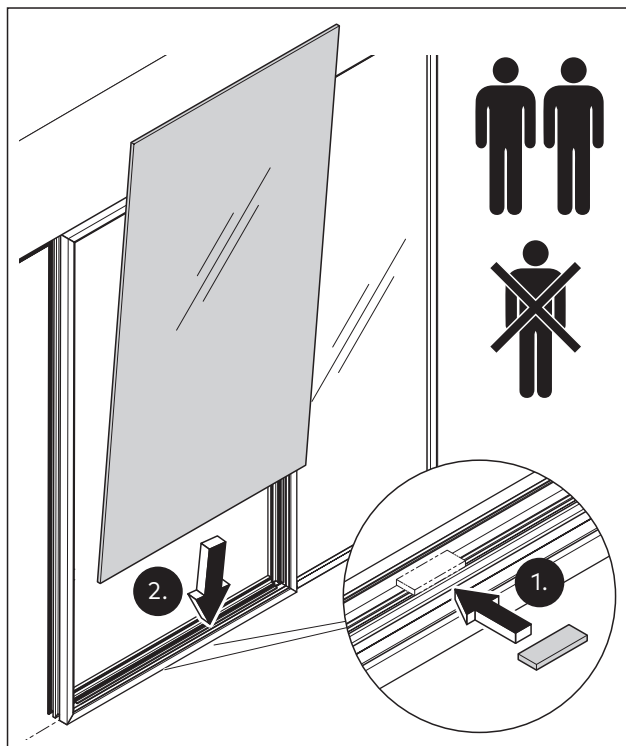

Fig. 33 Working in a pair, place the glass on the wooden blocks

3. Prepare the vertical wooden blocks to maintain the corresponding vertical clearance(Fig. 34).
4. Align the glass vertically.

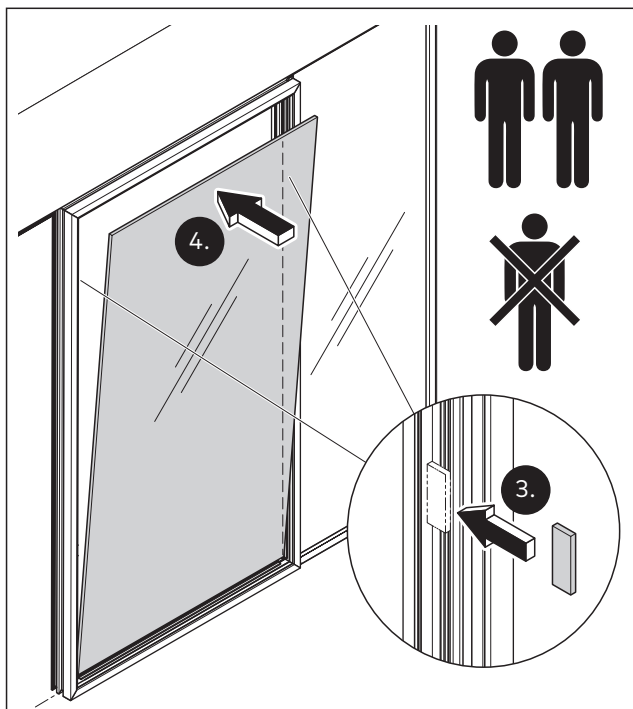

Fig. 34 Align the glass vertically

5. Maintain the distance between the clamping pieces of approx. 80 mm to the corner (Fig. 35).
6. Fix the glass with 3 clamping pieces per meter on the base profile vertically and horizontally with a torque of 5 Nm.

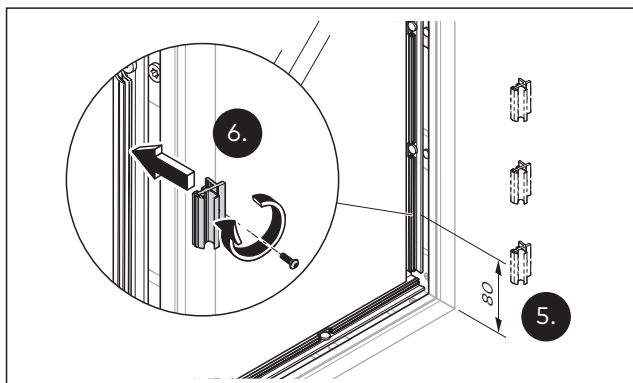

Fig. 35 Example of attaching clamping pieces to the vertical base profile and glass

6.6 Attach sound-absorbing material and frameless textile banner

Requirements

- The glass is attached

Determine the width and height of the sound-absorbing material and the textile banners according to the dimensions of the acoustic element frame (see Chapter 3.4).

6.6.1 Attach sound-absorbing material



TIPS AND RECOMMENDATIONS

The following is recommended for sound absorption:

- Acoustic bubble foam
- format: 1000 mm x 500 mm x 40 mm
- self-adhesive on one side
- fire protection class according to the building code's specification

1. Cut the sound-absorbing material and attach it to the entire surface of the glass (Fig. 36).

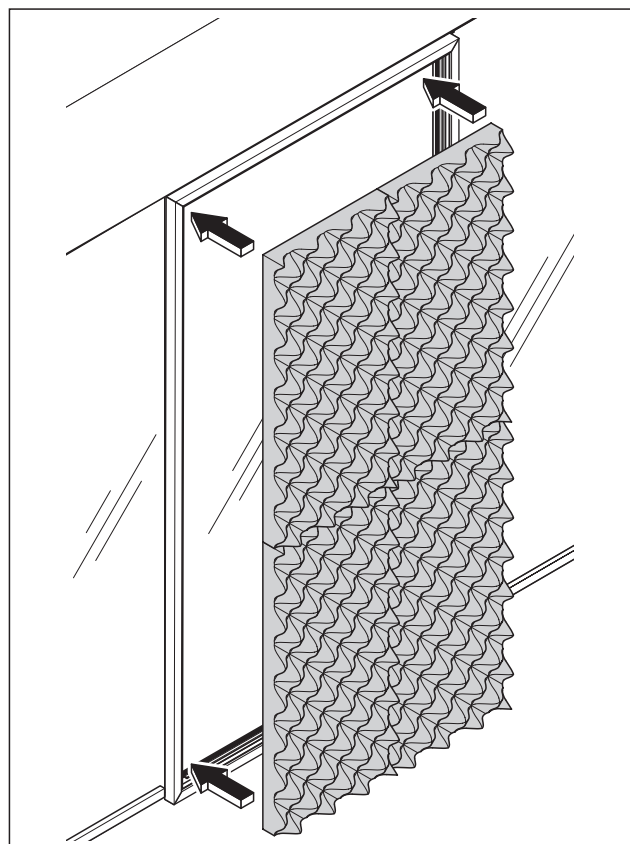

Fig. 36 Apply the sound-absorbing material over the entire surface of the glass

6.6.2 Attach frameless textile banner



TIPS AND RECOMMENDATIONS

For the textile banner, Trevira CS 300g/m² with one side white or both sides printed with circumferential rubber piping 15 mm x 2.8 mm is recommended.



TIPS AND RECOMMENDATIONS

Do not warp the rubber piping, as otherwise there will be visible distortion in the motif and the fabric will not hang evenly in the profile.



TIPS AND RECOMMENDATIONS

Before attaching a textile banner, make sure that the textile banner is provided for the corresponding side of the acoustic element.



TIPS AND RECOMMENDATIONS

The textile banner can be replaced at any time by another textile banner, e.g. in the event of hard-to-remove stains.

1. Completely fold in the circumferentially sewn rubber piping inwards(Fig. 37).

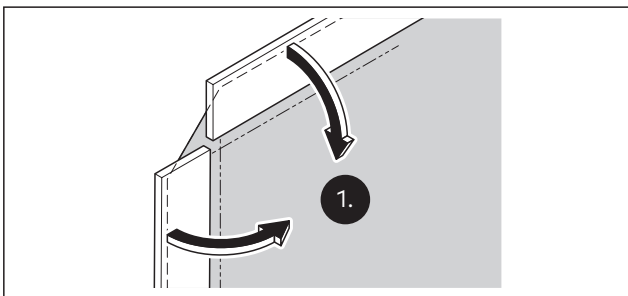

Fig. 37 Completely fold in the circumferentially sewn rubber piping inwards

2. Press the rubber piping from the top left outwards into the horizontal and vertical groove to the middle of the two profile sides (Fig. 38).

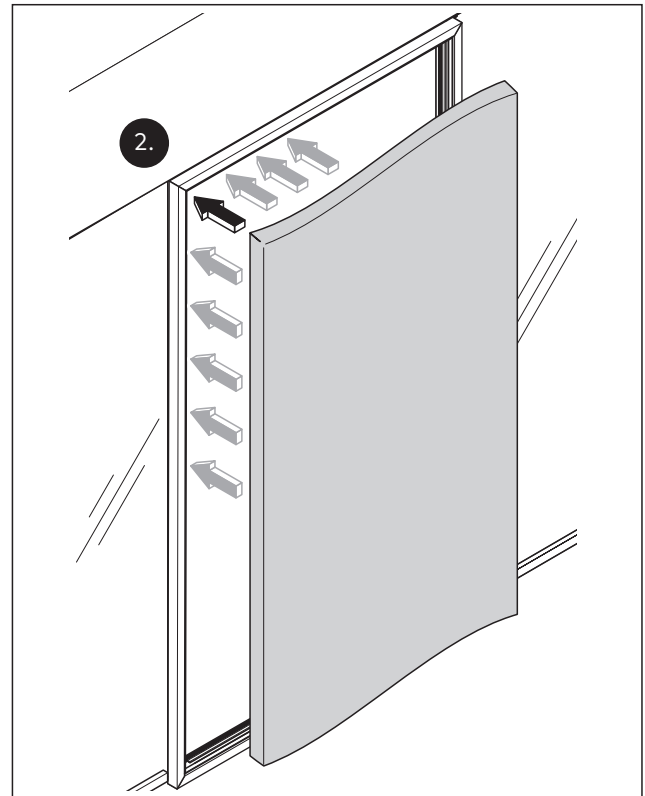

Fig. 38 Press the rubber piping from the top left into each groove to the middle of the two profile sides

3. Starting from the bottom right, press the rubber piping outwards into the horizontal and vertical groove to the middle of the two profile sides (Fig. 39).

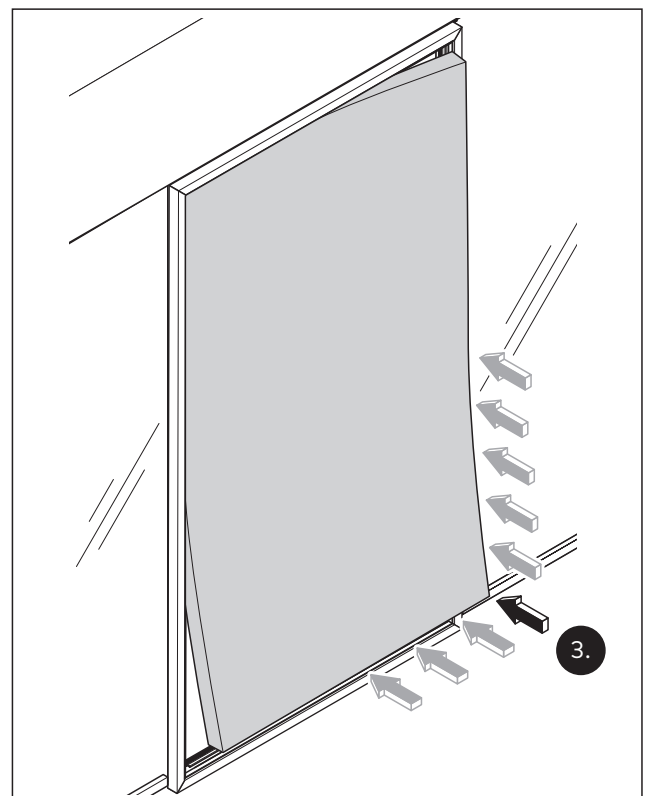

Fig. 39 Press the rubber piping in the lower right into the horizontal and vertical groove to the middle of the two profile sides

4. Press the rubber piping at the bottom right into the groove from the middle of the profile sides outwards to the corner (Fig. 40).

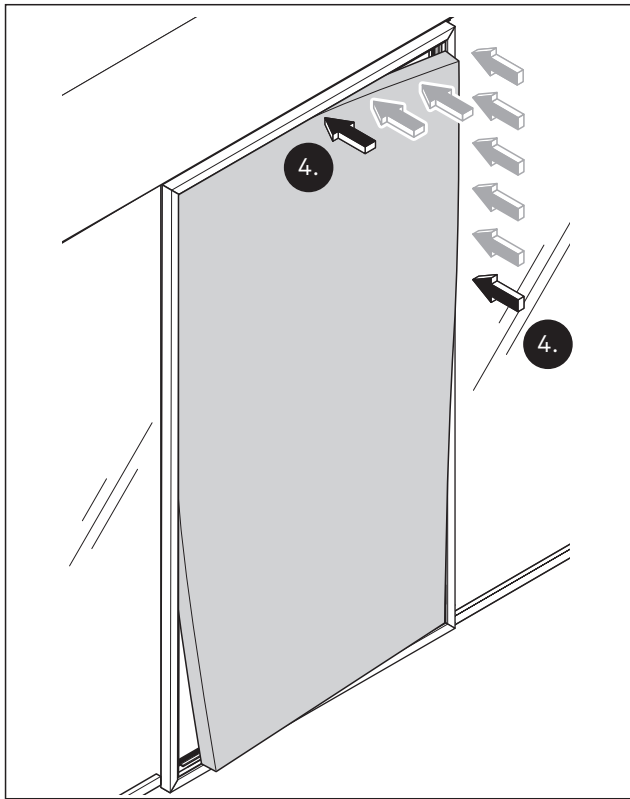

Fig. 40 Press the rubber piping at the top right into the groove from the center to the corner

5. Press the rubber piping on the bottom left into the groove from the middle of the profile sides outwards to the corner (Fig. 41).

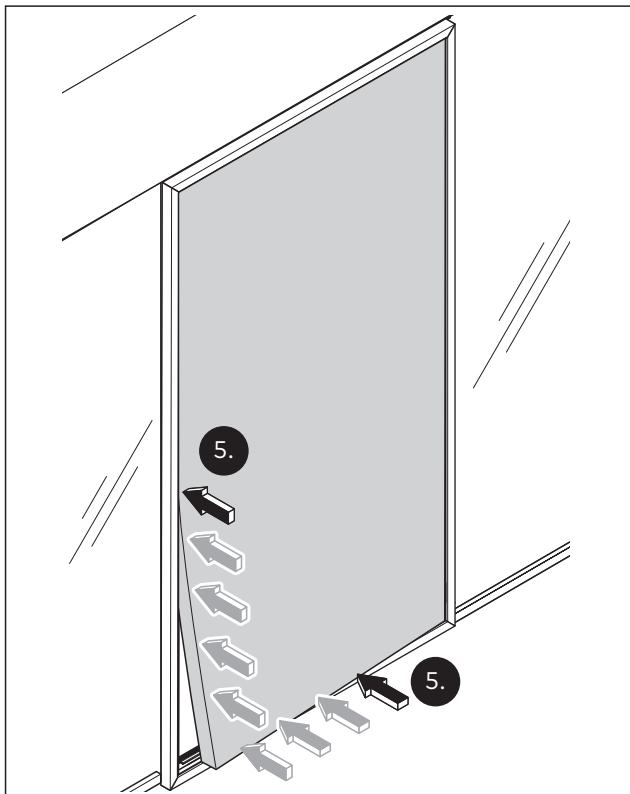

Fig. 41 Press the rubber piping at the bottom left into the groove from the center to the corner

6. Apply a second frameless textile banner on the opposite side of the acoustic element as described.

6.7 Complete mounting

Complete mounting the unit according to the unit components' enclosed mounting instructions.

7 Maintenance and care



CAUTION

Risk of injury due to cut edges

Touching the cut edges can lead to cuts, e.g. at the corner joint of an acoustic element.

- Wear protective gloves.

7.1 Maintenance instructions

The product is largely maintenance-free. Follow maintenance instructions for all unit components. Follow system manual.

7.2 Cleaning instructions

Only use suitable cleaning and care products to clean the surfaces.

8 Disassembly and disposal

Disassembly is carried out in the reverse order of the mounting instructions and must be done by qualified personnel. When disposing, observe the relevant national standards and guidelines.



Dispose of the product in an environmentally friendly manner.

Electrotechnical parts and batteries must not be disposed of with domestic waste.

Use designated acceptance collection points to

dispose of electro-technical parts and batteries.

Observe the applicable national legal regulations.

Translation of the original manual, subject to change without notice

UNIQIN Installation Anim. EN



DORMA-Glas GmbH

Max-Planck-Strasse 33-45 32107 Bad Salzufen Germany

T: +49 2333 793-0 F: +49 2333 793-4950

www.dormakaba.com